

ZS129A1



ZS129A2

ZS129A4

ZS129A5

ZS127Z1

Switch Units R&S ZS 129x

RF and IF signal distribution

The Switch Unit Family R&S ZS 129x is a cost-effective and reliable approach to RF and IF signal distribution. Its flexible concept allows adaptation to system requirements by adding optional extensions.

The R&S ZS 129x family offers the following outstanding features:

- ◆ Suitable for stationary, transportable and mobile applications
- ◆ Tried and tested in various systems
- ◆ Compact design
- ◆ Cost-effective realization of customer-specific solutions due to modular design and wide variety of units and modules
- ◆ Manual operation and remote control for optimum hardware and software interworking
- ◆ Additional outputs for controlling additional switch units via the same control interface



ROHDE & SCHWARZ

Introduction

Monitoring systems usually comprise several receiving antennas that have to be dynamically switched to the receivers in order to achieve the optimum system configuration for the individual tasks.

The Switch Units R&S ZS129x constitute an intelligent and flexible solution for stationary, transportable and mobile applications.

The R&S ZS129x family of universal switch units comprises the basic model R&S ZS129A1 as well as the models R&S ZS129A2, R&S ZS129A4, R&S ZS129A5 and R&S ZS127Z1 for enhanced capabilities.

Switch Unit R&S ZS129A1

The R&S ZS129A1 has been designed as an indoor RF and IF switch unit for stationary, transportable and mobile systems.

The following standard models of the R&S ZS129A1 are available:

- ◆ R&S ZS129A1 Model 02 with 1-out-of-12 switch, DC to 3 GHz
- ◆ R&S ZS129A1 Model 06 with 1-out-of-6 switch, DC to 3 GHz
- ◆ R&S ZS129A1 Model 08 with 1-out-of-8 switch, DC to 3 GHz
- ◆ R&S ZS129A1 Model 12 with 1-out-of-12 switch, DC to 3 GHz, unused inputs terminated into 50 Ω
- ◆ R&S ZS129A1 Model 16 with 1-out-of-6 switch, DC to 3 GHz, unused inputs terminated into 50 Ω
- ◆ R&S ZS129A1 Model 18 with 1-out-of-8 switch, DC to 3 GHz, unused inputs terminated into 50 Ω
- ◆ R&S ZS129A1 Model 22 with 2-out-of-2 switch, DC to 3 GHz

The R&S ZS129A1 comprises a switch, a control board, a chipcard reader, a front panel keypad, an alphanumeric display and a power supply covering an input voltage range from +10 V to +35 V DC. Up to 6 DC feeds can be integrated as options.

The DC feed (option R&S ZS129F1) is used to apply a DC voltage to the inner conductor of the antenna input. This is an ideal solution for the power supply of most active receiving antennas. The DC feed can supply a DC voltage of up to 30 V at a maximum current of 500 mA.

The switch unit is usually integrated into the rack at the operator position and connected to the system controller via a serial interface or USB interface or it is connected directly to the receiver via a TTL interface. It may be operated manually at its front panel keypad or remotely via the system software.

The TTL interface provides a maximum of 16 parallel TTL lines. This makes it possible to control both the internal and the external (via control outputs) RF switches directly from a receiver with TTL control output.

When the R&S ZS129A1 is operated manually, the user enters the requested setting via the front panel keypad. The switch unit guides the user by means of menus that are adapted to the individual system configuration. The current settings and relevant parameters can be read from the alphanumeric display.

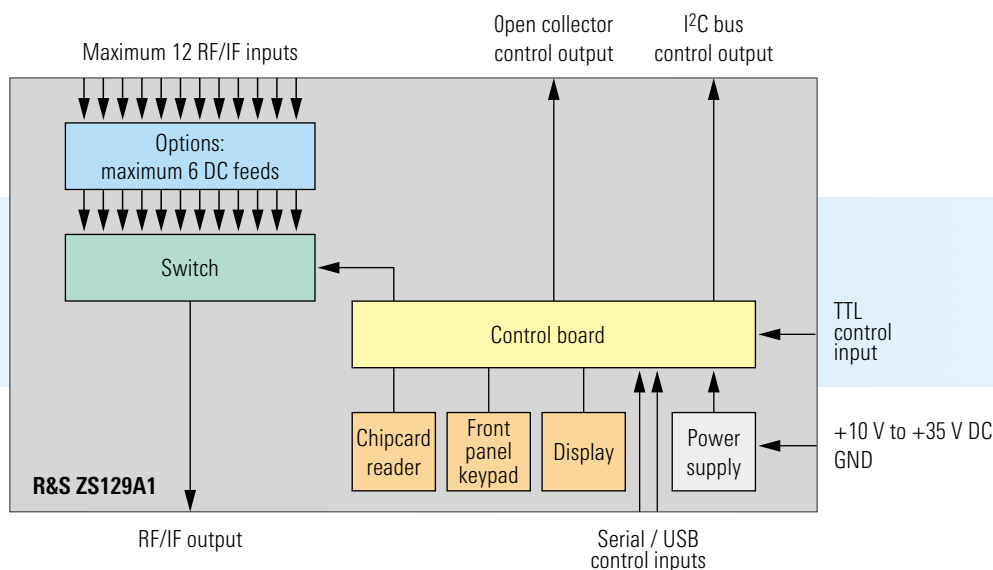

Block diagram of R&S ZS129A1

The R&S ZS129A1 has two control outputs on its rear panel to control external units:

- ◆ One I²C bus control output comprising an I²C bus interface, the +28 V DC supply and GND, for connecting an R&S ZS129A2 or an R&S ZS129A5 (to control one switch)
- ◆ One open collector control output comprising four independent control lines, the +28 V DC supply and GND, for connecting an R&S ZS129A4, an R&S ZS129A5 (to control up to four 1-out-of-2 switches or two 1-out-of-3 switches or two 1-out-of-4 switches) or up to four R&S ZS127Z1

The functionality of the system can thus be enhanced without a second control unit being required.

If several DC feeds are integrated or several units are connected, you must remember that the maximum supply current is 1.3 A.

The basic firmware of the R&S ZS129A1 is identical for each unit. Customer and system-specific information is defined and stored on a chipcard.

If the switch unit is delivered as part of a complete monitoring system, the chipcard will usually be programmed to the system-specific configuration by Rohde & Schwarz.

However, programming may also be performed by the customer. A null modem cable connected to the R&S ZS129A1 and the R&S ZS129x Card Editor, which runs under Windows XP, Windows 2000 or Windows NT4.0, are required to read from and write to the chipcard.



Front view of R&S ZS129A1



Rear view of R&S ZS129A1

When the chipcard is inserted into the chipcard reader, the Switch Unit R&S ZS129A1 is configured automatically for the system in question.

The following information is stored on the chipcard:

- ◆ Function of the commands for the switch and the control outputs
- ◆ Text to be output on the display

The card editor and the latest firmware are available at www.argus.rohde-schwarz.com.

Switch Unit R&S ZS 129A2

The Switch Unit R&S ZS 129A2 has been designed as an outdoor unit for mounting on top of masts close to receiving antennas. The length of the RF cables between the antennas and the switch unit can be minimized, and only one RF cable and one control cable need to be routed to the equipment inside the station.

The R&S ZS 129A2 comprises a control board, a 1-out-of-8 switch, one DC feed and lightning protection for the RF output. As an option, the unit may also be equipped with 2 additional DC feeds (option R&S ZS 129F1) to supply power to more than one active antenna.

The R&S ZS 129A2 is controlled from the Switch Unit R&S ZS 129A1 or from the Antenna Control Units R&S GB 127S or R&S GB 127M.

The R&S ZS 129A2 is operated via the I²C bus control interface. A single control cable is used, incorporating an I²C bus interface, a +28 V DC supply and GND. The control cables supplied by Rohde & Schwarz for connecting the control unit and the R&S ZS 129A2 have been tested



Front view of R&S ZS 129A2

for lengths up to 120 m. (For ranges in excess of 30 m, the control cable for the I²C bus interface and the +28 V DC supply is split). The connection between the two units requires additional lightning protection at the point of entry into the building.

The R&S ZS 129A2 has two control outputs on its rear panel to control external units:

- ◆ One I²C bus control output comprising an I²C bus interface, the +28 V DC supply and GND, for connecting an R&S ZS 129A2 or an R&S RD 127 (only

if the R&S ZS 129A2 is controlled from the Antenna Control Units R&S GB 127S or R&S GB 127M)

- ◆ One open collector control output comprising four independent control lines, the +28 V DC supply and GND, for connecting an R&S ZS 129A4 or up to four R&S ZS 127Z1

The functionality of the system can thus be enhanced without an additional control unit or another control cable from the control unit to the external unit on the mast.

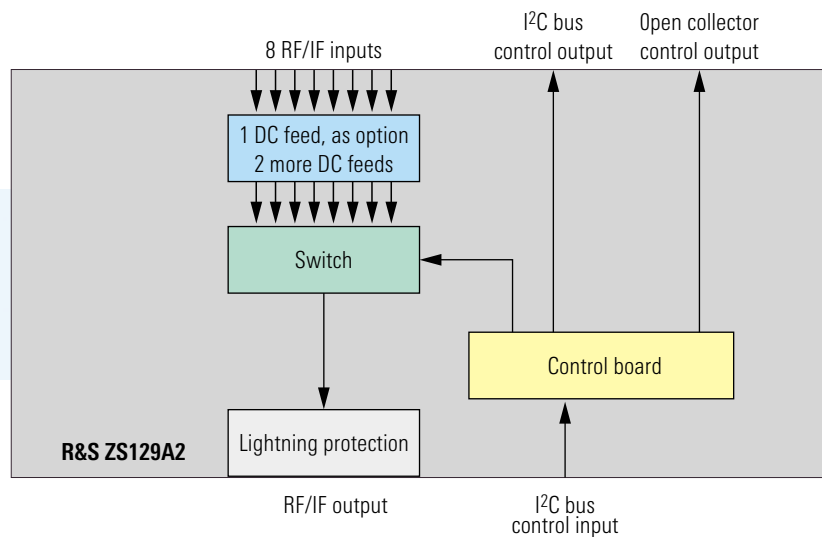

Block diagram of R&S ZS 129A2

Switch Unit R&S ZS 129A4

The Switch Unit R&S ZS 129A4 has been designed as an outdoor unit for mounting on a vehicle's roof (preferably beneath the sunroof, close to the receiving antennas). The length of the RF cables between the antennas and the switch unit can be minimized, and only two RF cables and one control cable need to be routed to the equipment inside the vehicle.

The R&S ZS 129A4 comprises two independent 1-out-of-3 switches and one DC feed to supply power for one active antenna.

The R&S ZS 129A4 is remotely controlled from the Switch Unit R&S ZS 129A1 or from the Antenna Control Units R&S GB 127S or R&S GB 127M via the control input. A single control cable is used, incorporating four switched GND control lines, a +28 V DC supply and GND. The control cable supplied by Rohde & Schwarz has been tested for lengths up to 10 m.



Front view of R&S ZS 129A4

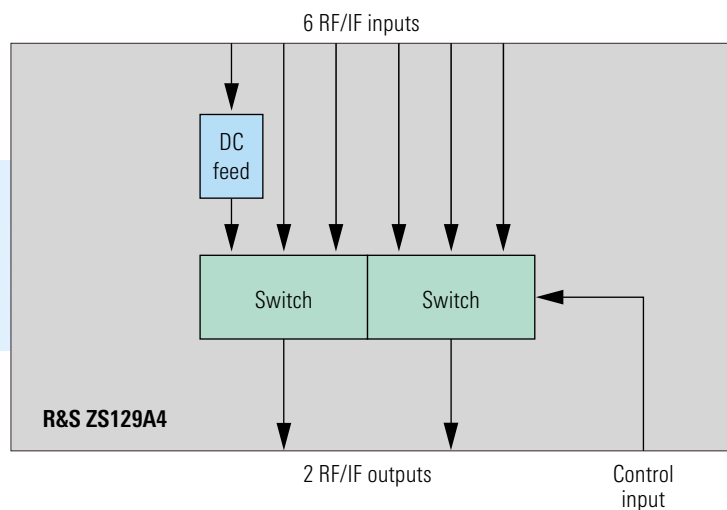

Block diagram of R&S ZS129A4

Switch Unit R&S ZS129A5

The configurable Switch Unit R&S ZS129A5 is ideal for a wide variety of indoor RF and IF switching applications. Its flexible concept allows adaptation to system requirements by adding optional modules. The R&S ZS129A5 is of modular design. Various switches, power splitters and DC feeds can be integrated into an empty prefabricated enclosure to meet specific requirements.

The basic unit is a rugged 19" rackmount with a height of two units for easy integration into system racks. Since the R&S ZS129A5 does not have to be operated manually, it can be located at a remote position, e.g. somewhere inside a rack so that no space is wasted at the front. The basic unit comprises an integrated connection board and connectors for control inputs, control outputs and an optional external power supply. Inside, there is a lot of space to integrate optional modules.



Rear view of R&S ZS129A5 equipped with 1-out-of-8 switch and 1-out-of-2 switch

The following switch modules have been designed as standard for the R&S ZS129A5:

- ◆ R&S ZS129S1: 1-out-of-2, DC to 3 GHz
- ◆ R&S ZS129S2: 1-out-of-6, DC to 3 GHz
- ◆ R&S ZS129S3: 1-out-of-8, DC to 3 GHz
- ◆ R&S ZS129S4: 1-out-of-2, DC to 3 GHz, unused inputs terminated into 50 Ω
- ◆ R&S ZS129S7: 1-out-of-6, DC to 3 GHz, unused inputs terminated into 50 Ω
- ◆ R&S ZS129S6: 1-out-of-8, DC to 3 GHz, unused inputs terminated into 50 Ω
- ◆ R&S ZS129S5: 2-out-of-2, DC to 3 GHz

The power splitter (option R&S ZS129M1), which can be integrated into the basic unit, is a cost-effective solution for taking a signal to two outputs in the frequency range from DC to 4 GHz. Since this module is a resistive power splitter with low output decoupling, it can be combined only with terminated relays.

The DC feed (option R&S ZS129F1) is used to supply power to one active antenna.

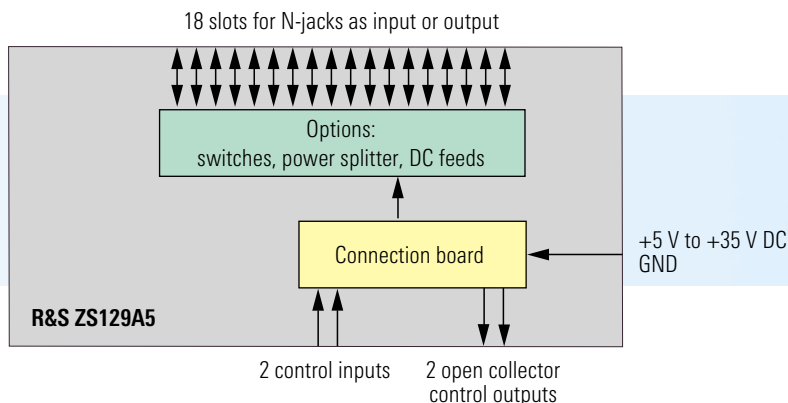

Block diagram of R&S ZS129A5

The R&S ZS 129A5 is remotely controlled from the Switch Unit R&S ZS 129A1 or from the Antenna Control Units R&S GB 127S or R&S GB 127M via the control inputs.

The switch unit is operated via three control inputs:

- ◆ Two control inputs comprising eight independent switched GND control lines, the +28 V DC supply and GND; the number of switches that can be controlled depends on the number of control lines; the control cable supplied by Rohde & Schwarz has been tested for lengths of up to 10 m.
- ◆ If the I²C control board (option R&S ZS 129C1) is included: one I²C bus control input comprising an I²C bus interface, the +28 V DC supply and GND; in this case, the two open collector control inputs are disconnected internally. Internally, a maximum of 16 independent control lines can be used to control the switches. The control cable supplied by Rohde & Schwarz has been tested for lengths of up to 120 m.

For special purposes, two open collector control outputs are provided in order to connect additional units, e.g. to cascade two or more units.

The power connector (+5 V to +35 V DC supply and GND) may be used to feed an external supply voltage for active modules, e.g. when an amplifier or additional DC feed is integrated in the R&S ZS 129A5.

The backplane can be equipped with up to 18 N jacks, used as inputs or outputs, depending on the individual configuration.

Owing to its modular concept, the hardware of the switch unit is easy to configure. The number of components used is limited by the space in the basic unit, the number of the control lines of the controlling units and the current drain. The Rohde & Schwarz Software R&S ZS 129A5 Configurator makes for easy setup of the required switch unit. Microsoft Excel is required for this tool.

The configurator is available at www.argus.rohde-schwarz.com.

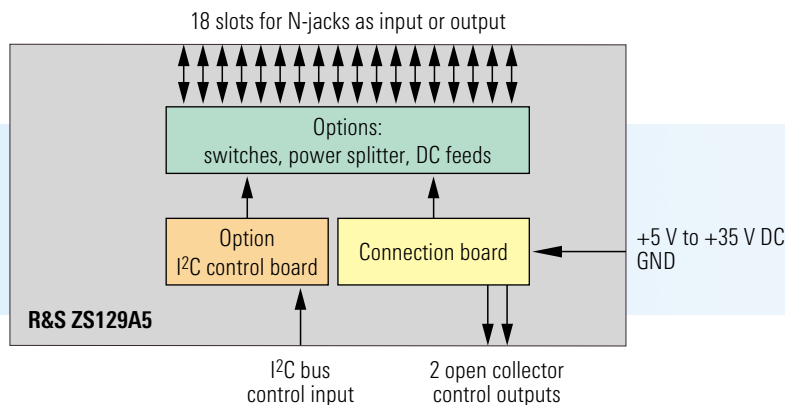

Block diagram of R&S ZS 129A5 with I²C control board option

Example 1:

Three independent switches, 1-out-of-3, unused inputs terminated, each implemented by means of two R&S ZS 129S4.

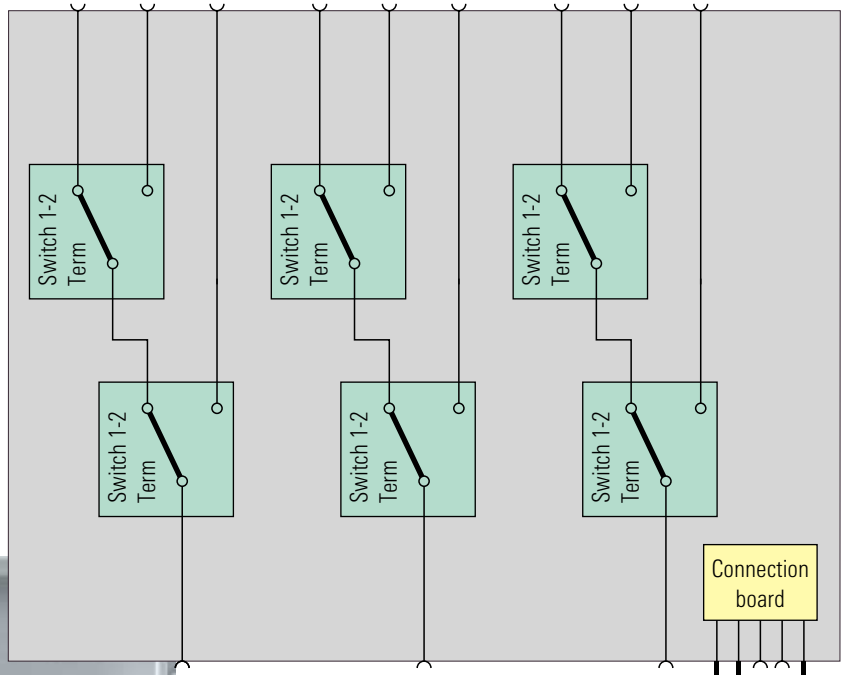
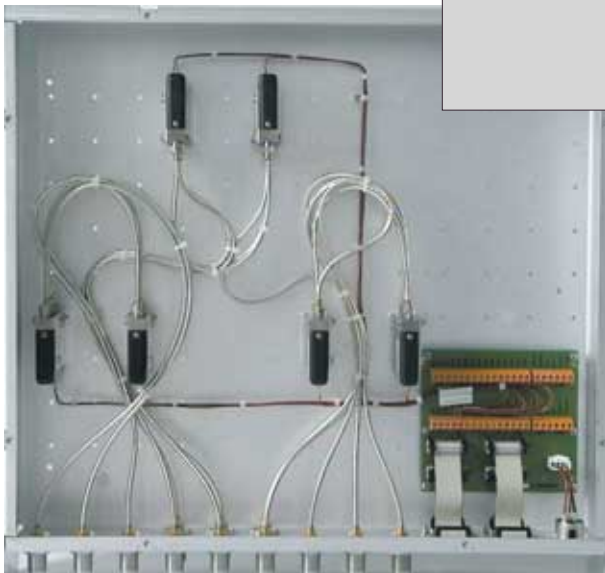

Example 2:

One switch, 1-out-of-4, implemented by three R&S ZS 129S1, a feed-through and two R&S ZS 129F1.

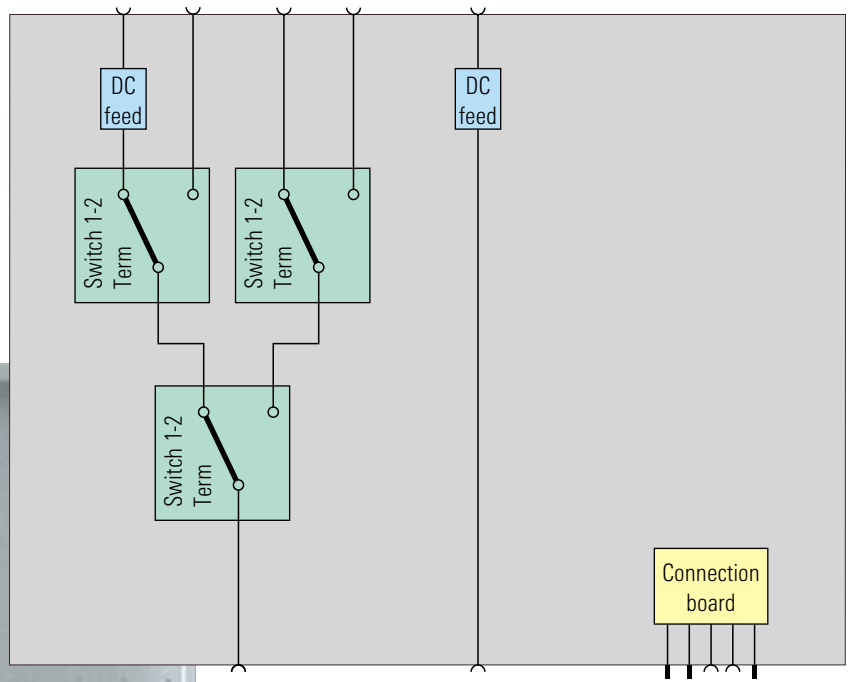
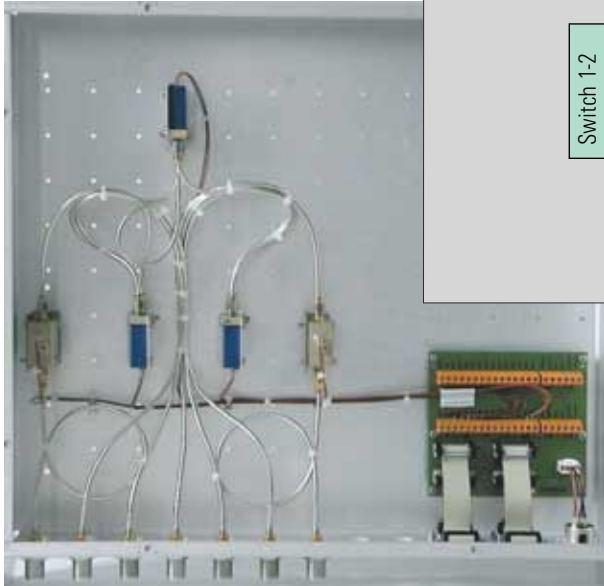

Example 3:

One switch, 1-out-of-5, implemented by one R&S ZS 129S2 and one R&S ZS 129F1.

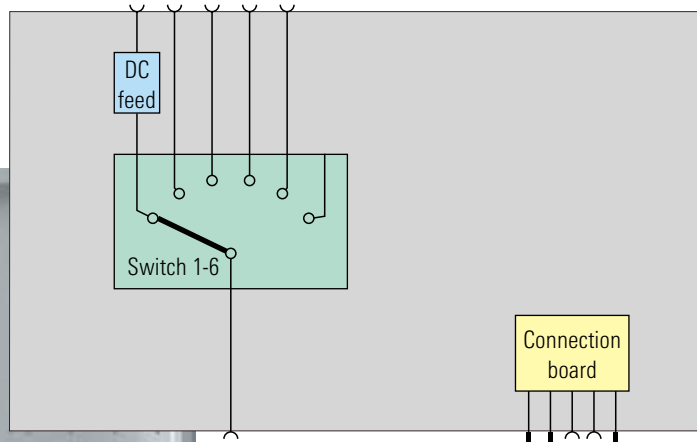
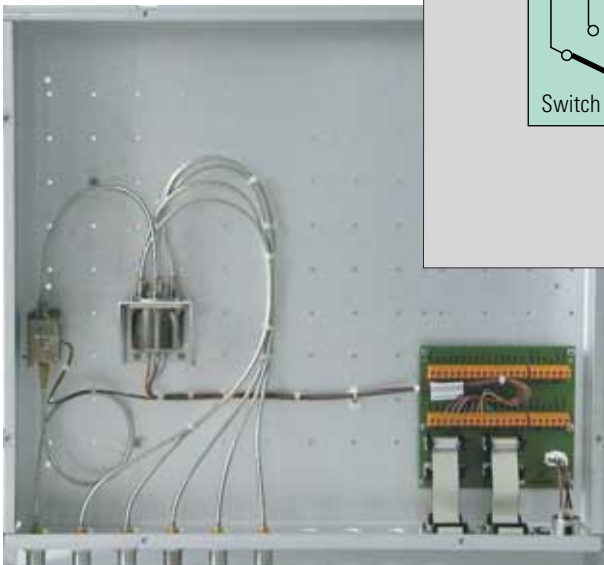

Switch Unit R&S ZS 127Z1

The Switch Unit R&S ZS 127Z1 has been designed as an outdoor unit to extend the switching functionality of other switch units.

The R&S ZS 127Z1 comprises a 1-out-of-2 switch.

The R&S ZS 127Z1 is remotely controlled from the Switch Unit R&S ZS 129A1 or from the Antenna Control Units R&S GB 127S or R&S GB 127M via the control input. A single control cable is used, incorporating a +28 V DC supply and a switched GND control line. The control cable supplied by Rohde & Schwarz has been tested for lengths up to 10 m.

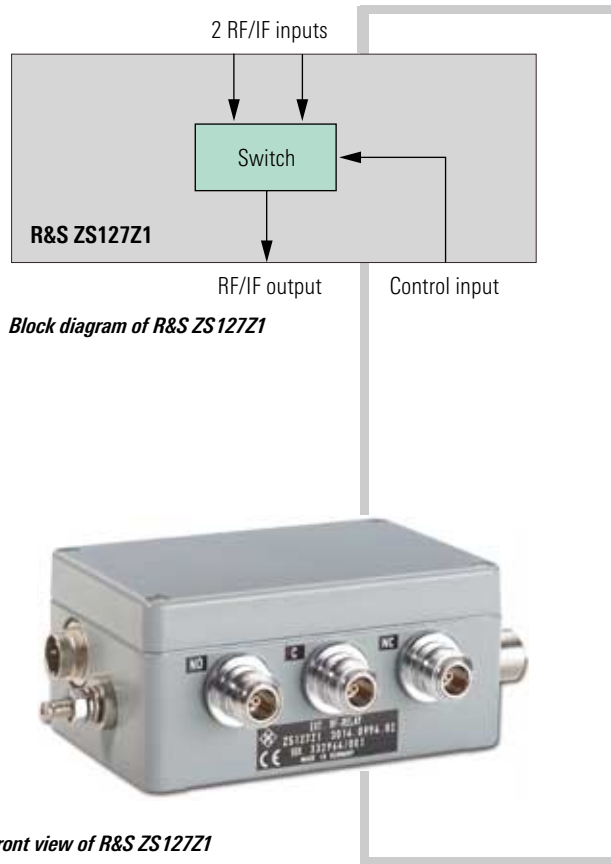

Front view of R&S ZS 127Z1

Multicouplers

When it comes to distributing antenna signals to more than one receiver at the same time, a multicoupler is most often the best choice. A multicoupler consists of an RF amplifier followed by a power splitter.

The amplifier compensates for the insertion loss of the power splitter, so that the overall gain is about 0 dB to +3 dB.

Owing to the high output isolation, in most cases, expensive terminated RF switches can be avoided and standard switch modules may be used.

Upon request, Rohde & Schwarz provides different multicouplers as separate 19" rackmounts for the following frequency ranges:

- ◆ (10 kHz) 100 kHz to 80 MHz, 4 or 8 outputs, for example suitable for the Antennas R&S HE010, R&S HE011, R&S HUF-Z2
- ◆ 20 MHz to 1300 MHz, 4 or 8 outputs, for example suitable for the Antennas R&S HE 309, R&S HE 314A1, R&S HF 214, R&S HK014, R&S HK309, R&S HL023A1/A2
- ◆ 1000 MHz to 3000 MHz, 4 or 8 outputs, for example suitable for the Antenna R&S HF902

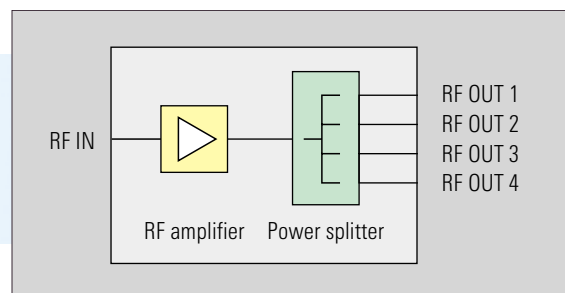

Block diagram of multicoupler

Specifications

R&S ZS 129A1

RF data	
Frequency range	DC to 3 GHz
Input VSWR	Signal paths without DC feed: ≤1.4 (DC to 3 GHz) ≤1.2 typ. at 1.3 GHz Signal paths with DC feed: ≤1.4 (100 kHz to 3 GHz) ≤1.2 typ. at 1.3 GHz
Insertion loss (in/out)	Signal paths without DC feed: ≤0.6 dB (DC to 1.3 GHz) ≤1.2 dB (DC to 3 GHz) Signal paths with DC feed: ≤1.2 dB (100 kHz to 1.3 GHz) ≤2 dB (100 kHz to 3 GHz)
Impedance	50 Ω
RF power (cold switching)	≤50 W (models 02/06/08) ≤1.0 W per input, ≤3.0 W total (models 12/16/18)
Switching time	≤15 ms
Interfaces	
RF INPUTS	N jacks (X1 to X12)
RF OUTPUT	N jack (X13)
COM1	D-Sub plug, 9 pins (X20), RS-232-C serial interface
USB	USB 1.1 (X30)
TTL IN	HD-Sub plug, 26 pins (X40), TTL control input
EXP1	D-Sub jack, 9 pins (X50), open collector control output
I ² C REM CTRL	D-Sub jack, 15 pins (X60), I ² C bus control output
POWER IN	D-Sub plug with high current contacts (X110)
General data	
Operating temperature range	0°C to +50°C
Storage temperature range	-40°C to +70°C
Humidity	95% relative humidity at +40°C
Sinusoidal vibration	5 Hz to 150 Hz
Random vibration	10 Hz to 300 Hz
Shock	40 g shock spectrum
EMC	meets EMC directive of EU (89/336/EEC) and German EMC law
Safety	meets EN 60950/VDE0805

Quality standard	developed and manufactured in compliance with ISO 9000
Power supply	+10 V to +35 V DC/max. 8 A/60 W
Dimensions (W x H x D)	19" rackmount 2 HU – 427 mm x 89 mm x 485 mm 484 mm x 89 mm x 495 mm (overall)
Weight	approx. 6 kg (depending on installed options)

R&S ZS 129A2

RF data	
Frequency range	DC to 3 GHz
Input VSWR	Signal paths without DC feed: ≤1.4 (DC to 3 GHz) ≤1.2 typ. at 1.3 GHz Signal paths with DC feed: ≤1.4 (100 kHz to 3 GHz) ≤1.2 typ. at 1.3 GHz
Insertion loss (in/out)	Signal paths without DC feed: ≤0.6 dB (DC to 1.3 GHz) ≤1.2 dB (DC to 3 GHz) Signal paths with DC feed: ≤1.2 dB (100 kHz to 1.3 GHz) ≤2 dB (100 kHz to 3 GHz)
Impedance	50 Ω
RF power (cold switching)	≤120 W
Switching time	≤15 ms
Interfaces	
X1 to X8	N jacks RF inputs from receiving antennas
OUTPUT	N jack (X10) RF output
CONTROL IN	MIL connector, 10-pin plug (X100)
CONTROL OUT	MIL connector, 10-pin jack (X60)
EXT/AUX	MIL connector, 6-pin jack (X50)
General data	
Operating temperature range	-35°C to +55°C
Storage temperature range	-40°C to +70°C
Humidity	95% relative humidity at +55°C
Sinusoidal vibration	5 Hz to 150 Hz
Random vibration	10 Hz to 300 Hz
Shock	40 g shock spectrum
EMC	meets EMC directive of EU (89/336/EEC) and German EMC law
Safety	meets EN 60950/VDE0805

Quality standard	developed and manufactured in compliance with ISO 9000
Power supply	+28 V DC (via control input)
Dimensions (W x H x D)	404 mm x 313 mm x 183 mm (without connectors) 404 mm x 335 mm x 183 mm (overall)
Weight	approx. 11.2 kg (depending on installed options)

R&S ZS 129A4

RF data	
Frequency range	DC to 3 GHz
Input VSWR	Signal paths without DC feed: ≤1.4 (DC to 3 GHz) ≤1.2 typ. at 1.3 GHz Signal paths with DC feed: ≤1.4 (100 kHz to 3 GHz) ≤1.2 typ. at 1.3 GHz
Insertion loss (in/out)	Signal paths without DC feed: ≤0.6 dB (DC to 1.3 GHz) ≤1.2 dB (DC to 3 GHz) Signal paths with DC feed: ≤1.2 dB (100 kHz to 1.3 GHz) ≤2 dB (100 kHz to 3 GHz)
Impedance	50 Ω
RF power (cold switching)	≤120 W
Switching time	≤15 ms
Interfaces	
X1 to X3/X5 to X7	N jacks RF inputs from receiving antennas
X9/X10	N jacks RF outputs
CONTROL	MIL connector, 10-pin plug (X100)
General data	
Operating temperature range	−35°C to +55°C
Storage temperature range	−40°C to +70°C
Humidity	95% relative humidity at +55°C
Sinusoidal vibration	5 Hz to 150 Hz
Random vibration	10 Hz to 300 Hz
Shock	40 g shock spectrum
EMC	meets EMC directive of EU (89/336/EEC) and German EMC law
Safety	meets EN 60950/VDE 0805

Quality standard	developed and manufactured in compliance with ISO 9000
Power supply	+28 V DC (via control input)
Dimensions (W x H x D)	258 mm x 159 mm x 92 mm (without connectors) 258 mm x 199 mm x 92 mm (overall)
Weight (basic version)	3.0 kg

R&S ZS 129A5

RF data	
Frequency range	DC to 3 GHz
Input VSWR	depending on hardware configuration
Insertion loss (in/out)	depending on hardware configuration
Impedance	50 Ω
Interfaces	
SIGNAL 1 to 18	RF inputs/outputs, depending on hardware configuration (unused connectors are not installed)
CTRL IN 1 and 2	D-Sub plugs, 15 pins (X21 and X22)
CTRL OUT 1 and 2	D-Sub jacks, 15 pins (X31 and X32)
POWER	round connector, 3 pins (X100)
SER CTRL	D-Sub plug, 9 pins (X23) (for I ² C control option)
General data	
Operating temperature range	−35°C to +55°C
Storage temperature range	−40°C to +70°C
Humidity	95% relative humidity at +55°C
Sinusoidal vibration	5 Hz to 150 Hz
Random vibration	10 Hz to 300 Hz
Shock	40 g shock spectrum
EMC	meets EMC directive of EU (89/336/EEC) and German EMC law
Quality standard	developed and manufactured in compliance with ISO 9000
Power supply	+28 V DC (via control input) or +5 V to +35 V DC (from external power supply)
Dimensions (W x H x D)	19" rackmount without front panel 2 HU – 450 mm x 85 mm x 460 mm
Weight	3.6 kg

Switches for R&S ZS129A5

RF data	
Frequency range	DC to 3 GHz
Input VSWR	≤1.4
Insertion loss (in/out)	≤1 dB
Impedance	50 Ω
RF power (cold switching)	R&S ZS 129S1: ≤70 W R&S ZS 129S2: ≤50 W R&S ZS 129S3: ≤50 W R&S ZS 129S4: ≤0.5 W R&S ZS 129S7: ≤1.0 W per input, ≤3.0 W total R&S ZS 129S6: ≤1.0 W per input, ≤3.0 W total R&S ZS 129S5: ≤50 W
Switching time	R&S ZS 129S1: ≤10 ms others: ≤15 ms
Life	R&S ZS 129S1: 5 000 000 operations R&S ZS 129S2: 1 000 000 operations others: 2 000 000 operations
Interfaces	
RF inputs	SMA jacks
RF output	SMA jack
CONTROL (wires)	R&S ZS 129S1: +28 V DC/60 mA, GND R&S ZS 129S2: +28 V DC/150 mA, CTRL 1 to 6 R&S ZS 129S3: +28 V DC/150 mA, CTRL 1 to 8 R&S ZS 129S4: +28 V DC/205 mA, GND R&S ZS 129S7: +28 V DC/150 mA, CTRL 1 to 6 R&S ZS 129S6: +28 V DC/150 mA, CTRL 1 to 8 R&S ZS 129S5: +28 V DC/140 mA, GND
General data	
Operating temperature range	R&S ZS 129S4: -40°C to +85°C R&S ZS 129S5: -55°C to +85°C others: -40°C to +70°C
Storage temperature range	-55°C to +85°C
Humidity	95% relative humidity at +55°C
Sinusoidal vibration	5 Hz to 150 Hz
Random vibration	10 Hz to 300 Hz
Shock	40 g shock spectrum
Quality standard	developed and manufactured in compliance with ISO 9000
Power supply	+28 V DC

Dimensions (W x H x D)	R&S ZS 129S1: 25 mm x 52 mm x 50 mm R&S ZS 129S2: 80 mm x 69 mm x 65 mm R&S ZS 129S3: 80 mm x 69 mm x 65 mm R&S ZS 129S4: 25 mm x 60 mm x 70 mm R&S ZS 129S7: 80 mm x 69 mm x 65 mm R&S ZS 129S6: 80 mm x 69 mm x 65 mm R&S ZS 129S5: 56 mm x 52 mm x 60 mm
Weight	R&S ZS 129S1: 0.1 kg R&S ZS 129S3, R&S ZS 129S6, R&S ZS 129S7: 0.3 kg R&S ZS 129S2, R&S ZS 129S4, R&S ZS 129S5: 0.2 kg

Power splitter for R&S ZS129A5

RF data	
Frequency range	DC to 4 GHz
Attenuation (in/out)	6.5 dB typ.
Attenuation (out/out)	>6 dB
Impedance	50 Ω
Max. input power	≤+27 dBm (no damage)
Interfaces	
RF IN	SMA plug
RF OUT 1 to 2	SMA plugs
General data	
Operating temperature range	-20°C to +65°C
Storage temperature range	-55°C to +100°C
Humidity	95% relative humidity at +55°C
Sinusoidal vibration	5 Hz to 150 Hz
Random vibration	10 Hz to 300 Hz
Shock	40 g shock spectrum
Quality standard	developed and manufactured in compliance with ISO 9000
Dimensions (W x H x D)	28 mm x 65 mm x 55 mm
Weight	0.1 kg

Certified Environmental System
ISO 14001
REG. NO 1954

Certified Quality System
ISO 9001
DQS REG. NO 1954

I²C control board for R&S ZS129A5

Interfaces	
SER CTRL	D-Sub plug, 9 pins (mounted as X23 at rear panel of the R&S ZS129A5)
CTRL 1 and 2	flat cables with 16-pin female connector
General data	
Operating temperature range	−35°C to +55°C
Storage temperature range	−40°C to +70°C
Humidity	95% relative humidity at +55°C
Sinusoidal vibration	5 Hz to 150 Hz
Random vibration	10 Hz to 300 Hz
Shock	40 g shock spectrum
Quality standard	developed and manufactured in compliance with ISO 9000
Power supply	+28 V DC
Dimensions (W x H x D)	123 mm x 31 mm x 53 mm (without cables)
Weight	0.2 kg

R&S ZS127Z1

RF data	
Frequency range	DC to 3 GHz
Input VSWR	≤1.4 (DC to 3 GHz) ≤1.2 typ. at 1.3 GHz
Insertion loss (in/out)	≤0.5 dB (DC to 1.3 GHz) ≤1 dB (DC to 3 GHz)
Impedance	50 Ω
RF power (cold switching)	≤120 W
Switching time	≤15 ms
Interfaces	
RF inputs	N jacks
RF output	N jack
CONTROL	3-pin plug pin 1 = GND pin 2 = n.c. pin 3 = +28 V DC/60 mA
General data	
Operating temperature range	−35°C to +55°C
Storage temperature range	−40°C to +70°C
Humidity	95% relative humidity at +55°C

Sinusoidal vibration	5 Hz to 150 Hz
Random vibration	10 Hz to 300 Hz
Shock	40 g shock spectrum
EMC	meets EMC directive of EU (89/336/EEC) and German EMC law
Safety	meets EN 60950/VDE 0805
Quality standard	developed and manufactured in compliance with ISO 9000
Power supply	+28 V DC
Dimensions (W x H x D)	125 mm x 80 mm x 58 mm (without connectors) 169 mm x 98 mm x 58 mm (overall)
Weight (basic version)	0.7 kg

DC feed for R&S ZS129A1, R&S ZS129A2 and R&S ZS129A5

RF data	
Frequency range	100 kHz to 3 GHz
Input VSWR	≤1.4
Insertion loss (in/out)	≤2 dB
Impedance	50 Ω
RF power	≤1 W
Interfaces	
RF	SMA jack
RF & DC	SMA plug
POWER	GND, up to +30 V DC/max. 500 mA (depending on antenna supplied from this unit)
General data	
Operating temperature range	−40°C to +70°C
Storage temperature range	−55°C to +85°C
Humidity	95% relative humidity at +55°C
Sinusoidal vibration	5 Hz to 150 Hz
Random vibration	10 Hz to 300 Hz
Shock	40 g shock spectrum
Quality standard	developed and manufactured in compliance with ISO 9000
Power supply	+28 V DC
Dimensions (W x H x D)	28 mm x 65 mm x 55 mm
Weight	0.1 kg

Ordering information

R&S ZS 129A1

Designation	Type	Order No.
Basic versions		
Switch Unit, 1-out-of-12, DC to 3 GHz <i>For indoor use, control via USB, RS-232-C or TTL interface and manual operation</i>	R&S ZS 129A1	3026.3012.02
Switch Unit, 1-out-of-6, DC to 3 GHz <i>For indoor use, control via USB, RS-232-C or TTL interface and manual operation</i>	R&S ZS 129A1	3026.3012.06
Switch Unit, 1-out-of-8, DC to 3 GHz <i>For indoor use, control via USB, RS-232-C or TTL interface and manual operation</i>	R&S ZS 129A1	3026.3012.08
Switch Unit, 1-out-of-12, DC to 3 GHz, unused inputs terminated into 50 Ω <i>For indoor use, control via USB, RS-232-C or TTL interface and manual operation</i>	R&S ZS 129A1	3026.3012.12
Switch Unit, 1-out-of-6, DC to 3 GHz, unused inputs terminated into 50 Ω <i>For indoor use, control via USB, RS-232-C or TTL interface and manual operation</i>	R&S ZS 129A1	3026.3012.16
Switch Unit, 1-out-of-8, DC to 3 GHz, unused inputs terminated into 50 Ω <i>For indoor use, control via USB, RS-232-C or TTL interface and manual operation</i>	R&S ZS 129A1	3026.3012.18
Switch Unit, 2-out-of-2, DC to 3 GHz <i>For indoor use, control via USB, RS-232-C or TTL interface and manual operation</i>	R&S ZS 129A1	3026.3012.22
Option		
DC Feed, 100 kHz to 3 GHz <i>Supplies up to 30 V DC at max. 500 mA</i>	R&S ZS 129F1	3024.6614.02

Additional options such as GaAs switches and switches for higher frequencies are available on request.

R&S ZS 129A2

Basic version		
Switch Unit, 1-out-of-8, DC to 3 GHz, with one DC feed <i>For outdoor use, control via R&S ZS 129A1, R&S GB 127S or R&S GB 127M</i>	R&S ZS 129A2	3023.2015.02
Option		
DC Feed, 100 kHz to 3 GHz <i>Supplies up to 30 V DC at max. 500 mA</i>	R&S ZS 129F1	3024.6614.02

Additional options such as the I²C bus control cable and the lightning protection set for the I²C bus control cable are available on request.

R&S ZS 129A4

Switch Unit, 2 x 1-out-of-3, DC to 3 GHz, with one DC feed <i>For outdoor use, control via R&S ZS 129A1, R&S GB 127S or R&S GB 127M</i>	R&S ZS 129A4	3023.2267.02
--	--------------	--------------

Additional options such as the open collector control cable are available on request.

R&S ZS 129A5

Basic version (can be ordered just in connection with other options)		
Basic module of configurable Switch Unit <i>For indoor use, control via R&S ZS 129A1, R&S GB 127S or R&S GB 127M</i>	R&S ZS 129A5	3023.2515.05
Options		
Switch, 1-out-of-2, DC to 3 GHz	R&S ZS 129S1	3024.6514.02
Switch, 1-out-of-6, DC to 3 GHz	R&S ZS 129S2	3024.6520.02
Switch, 1-out-of-8, DC to 3 GHz	R&S ZS 129S3	3024.6537.02
Switch, 1-out-of-2, DC to 3 GHz, unused inputs terminated into 50 Ω	R&S ZS 129S4	3024.6543.02
Switch, 1-out-of-6, DC to 3 GHz, unused inputs terminated into 50 Ω	R&S ZS 129S7	3024.6572.02
Switch, 1-out-of-8, DC to 3 GHz, unused inputs terminated into 50 Ω	R&S ZS 129S6	3024.6566.02
Switch, 2-out-of-2, DC to 3 GHz	R&S ZS 129S5	3024.6550.02
DC Feed, 100 kHz to 3 GHz <i>Supplies up to 30 V DC at max. 500 mA</i>	R&S ZS 129F1	3024.6614.02
Power Splitter, 2 ways – 0 degree, resistive, DC to 4 GHz	R&S ZS 129M1	3025.4515.02
I ² C Bus Control Board	R&S ZS 129C1	3024.6714.02

Additional options such as switches for higher frequencies, the I²C bus control cable, the lightning protection set for the I²C bus control cable, the open collector control cable and the 19" front panel (2 HU) are available on request.

R&S ZS 127Z1

Switch Unit, 1-out-of-2, DC to 3 GHz <i>For outdoor use, control via R&S ZS 129A1, R&S GB 127S or R&S GB 127M, 28 V DC operation, with 5 m cable</i>	R&S ZS 127Z1	3014.0994.02
---	--------------	--------------



ROHDE & SCHWARZ

ROHDE & SCHWARZ GmbH & Co. KG · Mühlendorfstraße 15 · 81671 München · Germany

P.O.B. 801469 · 81614 München · Germany · Telephone +49 89 4129-0 · Fax +49 89 4129-13247 · www.rohde-schwarz.com